



AquaMetrix AM-ODO-TX
Optical Dissolved Oxygen Probe



Installation and Operation Manual

Contents

1. Introduction	3
2. Safety	3
3. Getting Started.....	4
4. ODO-TX Sensor and Specifications.....	4
4.1. System Description	4
4.2. Specifications	5
4.3. Dimensions.....	6
4.4. Connections to power supply and controller	6
5. Installation	7
6. Communication.....	8
6.1. Analog	8
6.2. Modbus	9
6.2.1. Common Registers	9
6.2.2. Sensor Status Registers	9
6.2.3. Device Specific Register 0042 Data Quality ID	9
6.2.4. Device Specific Registers.....	10
6.2.5. Calibration Registers	13
6.2.6. Sensor Health Table	15
7. Calibration.....	17
7.1. One Point Calibration: Water-Saturated-Air 100% Saturation	17
7.2. Second Point (0%) of Two Point Calibration	17
7.3. Temperature and Concentration (ppm or mg/l) calibration	17
8. Maintenance	18
8.1. Cleaning.....	18
8.2. Replacing the Sensor Cap.....	18
9. Spare Parts	19
10. Accessories.....	19
10.1. Calibration Cap.....	19
10.2. Mounting.....	20
10.2.1. General Installation Requirements	20
10.2.2. Submersion Mounting with the AM-ARM-5	20
10.2.3. Inline Mounting with the AM-TEE-5	21

11. Troubleshooting.....	23
12. Disposal.....	23
13. Contact.....	23
Appendix A: Dissolved Oxygen Equations.....	25
Appendix B: Commkit	27
Appendix C: Definitions.....	32

1. Introduction

The AM-ODO is one of the most compact, durable, and easiest to use dissolved oxygen sensors on the market. It is an optical sensor that utilizes fluorescence quenching technology. With this technology, the quenching of fluorophores by dissolved oxygen molecules decreases the fluorescence intensity and lifetime, the latter of which is detected by a photodetector and allows the dissolved oxygen (DO) concentration to be quantified accurately and consistently. Unlike polarographic and galvanic electrochemical technologies used for the measurement of dissolved oxygen, optical technology does not consume oxygen during measurement. Also, optical technology does not require electrolyte, a “warm-up” period, nor sample flow. The measured dissolved oxygen concentration is automatically compensated for by integrated data from the temperature and pressure sensors and sophisticated algorithms in the firmware.

The AM-ODO-TX is part of the AquaMetrix smart sensor series. Probes in this series are Direct Output Digital Sensors with the precision of a controller and the accuracy of our core probes. The AM-ODO-TX also can communicate via RS485 or Modbus protocol.

The AM-ODO-TX has two (2) analog outputs that can be mapped to Percent Saturation (%), concentration (mg/l) or Temperature. The %-saturation measurement is a function of atmospheric pressure while the concentration value is also a function of temperature and salinity. The ODO-TX comes fully calibrated and can maintain this calibration for 1-2 years, depending on the environment it is installed in.

2. Safety



WARNING

Electrical hazard

Do not install the probe unless you have electrical training and you have read the instruction manual. The probes uses 8-36V power supply and improper installation and handling can result in injury or damage to surrounding equipment including this probe.



NOTICE

The probe should only be installed, stored and serviced in the manner described in this manual. Improper handling may result in damage to the unit and surrounding equipment and may void the warranty.

3. Getting Started

1. A temperature sensor is built into the probe body, close to the sensor cap. It should be completely immersed in the sample when taking measurements.
2. Avoid sensor cap touching organic solvent, scratching, and abusive collisions to strengthen and lengthen the working life of the sensor cap. Special care should be taken to clean the coating of cap, to dip probe and cap in fresh water, and then to tap dry the surface with a tissue. Do not wipe the coating surface.
3. Replace the sensor cap if the cap coating is faded or stripped away. **DO NOT touch the clear window on the probe tip after unscrewing the old cap.** If any contaminants or residue are present on the window or inside the cap, carefully remove them with a powder free wipe. Then re-screw the new sensor cap onto the probe.

4. ODO-TX Sensor and Specifications

4.1. System Description

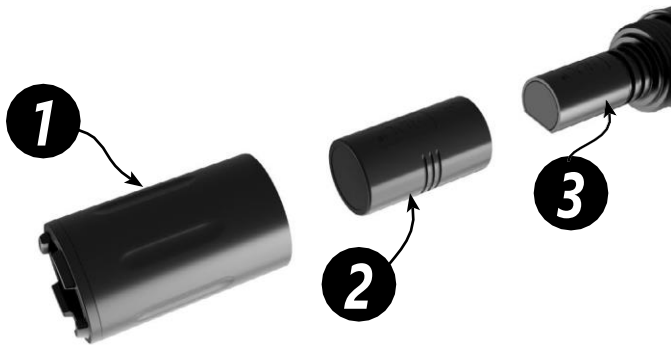

Your ODO-TX probe includes the following items:

- 1 The sensor guard cap protects and seals the sensor cap in place.
- 2 The membrane sensor cap (AM-ODO-TX-CAP) has a luminescent foil that responds to oxygen molecules. This cap needs to be replaced periodically; the typical life is two years.
- 3 The optical system contains the optics and circuitry that enable the sensor to calculate the concentration of dissolved oxygen.

4.2. Specifications

Probe Parameters	
Parameters	Optical Dissolved Oxygen Sensor
Data Transmission	Analog (4-20mA), RS485, Modbus
Range, DO	0-60 mg/L; 0-600% Saturation
Accuracy, DO	+/- 0.1 mg/L (0-20 mg/L)
	+/-2% (20-60 mg/L)
Resolution, DO	0.01 mg/L
Response Time, Cap	T63<5s, T90<45s, T95<60s
Units, DO	mg/L, ppm, % saturation
Range, Temp.	-5°C to 50°C (23°F to 122°F)
Accuracy, Temp	+/- 0.1°C
Resolution, Temp	0.01°C
Units, Temp	Celsius, Fahrenheit
Salinity Compensation	Fixed or real-time capable
Barometric Compensation	Fixed or real-time capable
Methods	EPA-approved methods 1002-8-2009,
	1003-8-2009, 1004-8-2009 Standard Methods 4500-O
Calibration	1-2 points via RS485 Connection OR at local controller
Calibration Time	~1 min (for each point)
Calibration Freq	1-2 years
Physical	
Wetted Material	PVC Body, Cycloy® (PC/ABS) ¹
	Ryton® (PPS), PC/PMMA ²
Reading Rate	1 second
Power Requirements	8 to 36 VDC
Power Consumption	Maximum (measurement): 50 mA at 12 VDC
	Idle (communication only): 2 mA at 12 VDC
IP Rating	IP-67 with sensor cap off; IP-68 with sensor cap installed
Compliance	EMC 2014/30/EU
	IEC 61000-6-2:2005
	EN 55011:2009

¹ Cycloy is a registered trademark of SABIC GLOBAL Technologies B.V.;

² Ryton is a registered trademark of Solvay SA.

Environmental	
Pressure	150 psi from 0° to 50°C
Depth	100 m (328 ft) @ 25°C
Operating Temperature (non-freezing)	-5°C to 50°C (23°F to 122°F)
Storage Temperature	-40°C to 65°C (-40°F to 149°F)
Interferences	Alcohols >5%; hydrogen peroxide > 3%; sodium hypochlorite (commercial bleach) > 3%; gaseous sulfur dioxide; gaseous chlorine. Do not use in organic solvents (e.g., acetone, chloroform, methylene chloride, etc.), which may swell the sensing element (foil matrix) and destroy it.

4.3. Dimensions

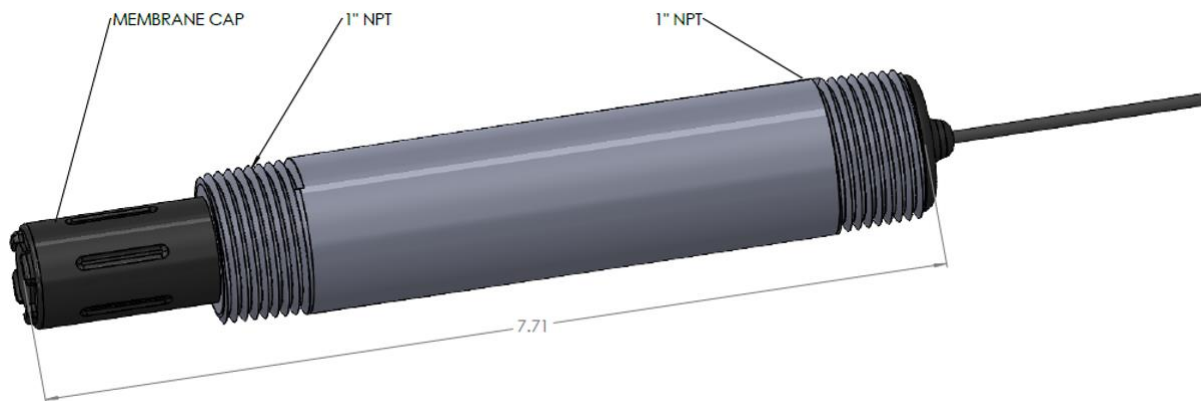

4.4. Connections to power supply and controller

Wire color	Description
Red	Power (8~ 36 VDC)
Black	GND (ground is shared between the power input and signal output, please make sure grounds are connected if external power supply is used)
Green	RS 485 B (+)
White	RS 485 A (-)
Blue	Analog Output 1 (configured using CommKit)
Yellow	Analog Output 2 (configured using CommKit)

- 1) The two RS485 wires can be cut if the user does not need PC monitoring or firmware updates.
- 2) Power supply: 5-36VDC. Make sure to follow the wiring instructions above and provide the proper power. Connecting the probe to any power outside the normal range may result in damage and may void the warranty.

5. Installation

The AM-ODO-TX can be connected to an AquaMetrix AM-2300 controller or any PLC. The probe can output either a single output or dual outputs. As factory default, the ODO-TX comes wired as such:

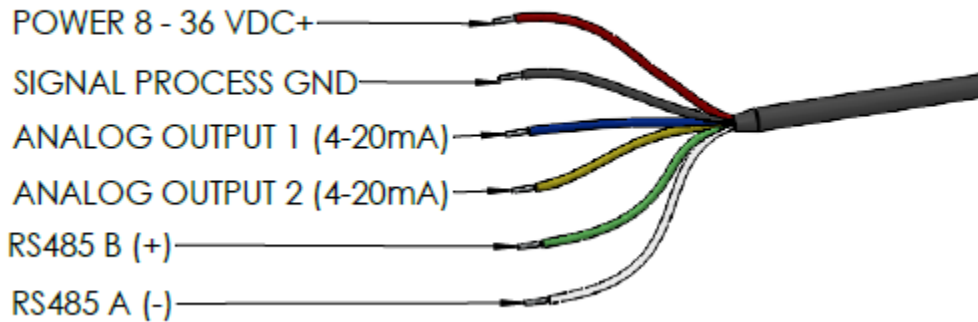

Using the RS485 connection the user can change the default analog outputs from the following selections: An optional configuration outputs the temperature or pressure as a second parameter. The AM-2300 can connect up to 4 AM-ODOTX sensors without use of an external power supply.

An external power supply may be required if the PLC doesn't have a 5-36VDC voltage source. The power ground and signal grounds must be connected.

Refer to the instructions below, as well as the controller/analyzer manual for proper installation and operation instructions.

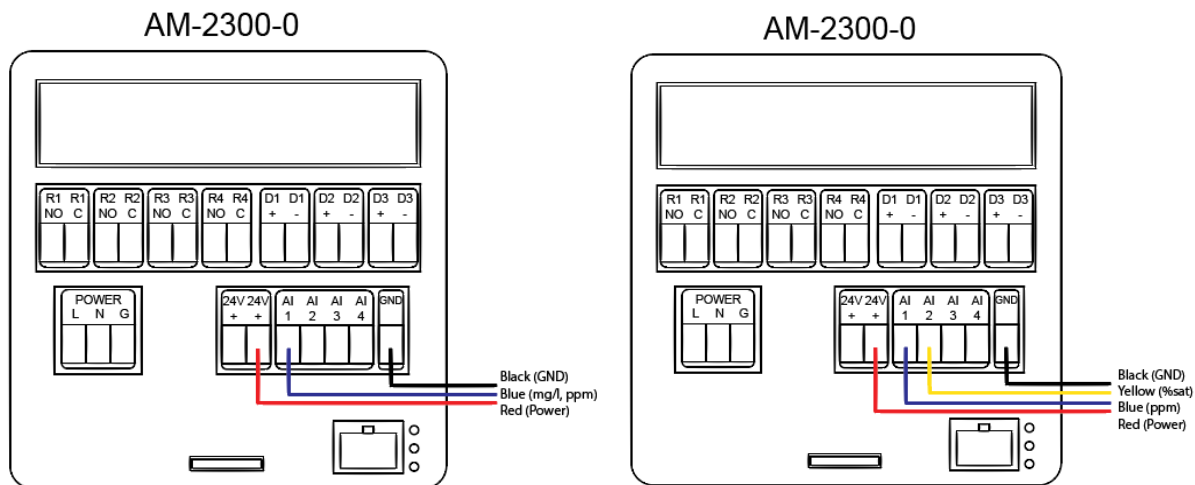

Figure 1- Wiring AM-ODO-TX to an AM-2300 controller.

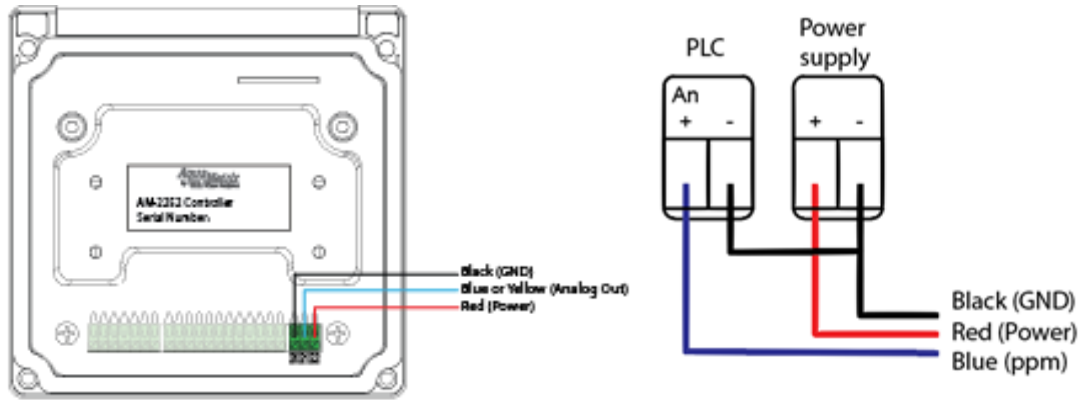

Figure 2- Wiring AM-ODO-TX to an AM-2252 or a PLC with an external power supply

6. Communication

6.1. Analog

The standard mapping for the ODO-TX analog output is:

Output	Output Parameter	4mA	20mA
Analog 1	Dissolved Oxygen (Percent Saturation)	0	200
Analog 2	Dissolved Oxygen (concentration)	0	20

The Two (2) Analog outputs can be remapped at the factory and by the customer

Output Parameter	Min	Max
Temperature	-5	50
Dissolved Oxygen (concentration)	0	60
Dissolved Oxygen (Percent Saturation)	0	600

6.2. Modbus

6.2.1. Common Registers

Register	Size	Mode & Access Level (R/W)	Data Type	Description
9001	1	R/W	ushort	Device ID = 36 or 37 (analog model)
9002	2	R/W	ulong	Device serial number
9004	3	R/W	time	Manufacture date

6.2.2. Sensor Status Registers

Register	Size	Mode & Access Level (R/W)	Data Type	Description
0005	3	R1	time	Cap start date/time 0 = no cap
0008	3	R1	time	Cap end of usable life date/time 0 = no cap

6.2.3. Device Specific Register 0042 Data Quality ID

Register 0042 is responsible for returning the various data quality IDs for the ODO-TX sensor. For a list of the Data Quality IDs and definitions, see the Sensor Health Table in the Service and Troubleshooting section of this manual.

6.2.4. Device Specific Registers

Register	Size	Mode & Access Level (R/W)	Data Type	Description
Dissolved Oxygen Concentration				
0038	2	R1	float	Measured value, Co
0040	1	R1	ushort	Parameter ID = 20
0041	1	R1/W2	ushort	Units ID 117 = mg/L (default) 118 = ug/L
0042	1	R1	ushort	Data quality ID (See the Sensor Health Table)
0043	2	R1/W3	float	Offline sentinel value (default = 0.0)
0045	1	R1	16 bits	Available units = 0x0030 (48)

Temperature

0046	2	R1	float	Measured value
0048	1	R1	ushort	Parameter ID = 1
0049	1	R1/W2	ushort	Units ID 1= °C (default) 2= °F
0050	1	R1	ushort	Data quality ID
0051	2	R1/W3	float	Offline sentinel value (default = 0.0)
0053	1	R1	16 bits	Available units = 0x00030 (3)

Dissolved Oxygen % Saturation

0054	2	R1	float	Measured value
0056	1	R1/W2	ushort	Parameter ID = 21
0057	1	R1/W2	ushort	Units ID 177 = percent saturation (default)
0058	1	R1	ushort	Data quality ID
0059	2	R1/W3	float	Offline sentinel value (default = 0.0)
0061	1	R1	16 bits	Available units = 0x0001 (1)

Oxygen Partial Pressure

0062	2	R1	float	Measured value
0064	1	R1	ushort	Parameter ID = 2 (pressure)
0065	1	R1/W2	ushort	Units ID 26 = torr (default)
0066	1	R1	ushort	Data quality ID
0067	2	R1/W3	float	Offline sentinel value (default = 0.0)
0069	1	R1	16 bits	Available Units = 0x0200 (512)

6.2.5. Calibration Registers

Register	Size	Mode & Access Level (R/W)	Data Type	Description
0118	2	R1/W3	float	Live salinity value (PSU)
0120	2	R1/W3	float	Default salinity value (PSU, default = 0.0)
0122	2	R1/W3	float	Live barometric pressure (mbar)
0124	2	R1/W3	float	Default barometric pressure (mbar, default = 1013.25)
0126	2	R1/W3	float	100% saturation calibration reading (mg/L)
0128	2	R1/W3	float	100% saturation temperature reading (°C)

0130	2	R1/W3	float	100% saturation salinity value (PSU)
0132	2	R1/W3	float	100% saturation barometric pressure (mbar)
0134	2	R1/W3	float	0% saturation calibration reading (mg/L)
0136	2	R1/W3	float	0% saturation temperature reading (°C)
0138	2	R1/W3	float	Calibration slope (default = 1.0)
0140	2	R1/W3	float	Calibration offset (default = 0.0)

6.2.6. Sensor Health Table

The instrument records a data quality ID between 0 and 7 with each reading. This ID indicates whether errors occurred during the reading. It is stored in the instrument's data quality register. See the table below for details.

Abbreviation	Data Quality ID	Text	Description
None	0	None	Normal Data Quality Parameter measured without errors using an expired user calibration.
UC	1	User Cal Expired	Parameter measured without errors using an expired factory calibration.
FC	2	Factory Cal Expired	
ERR	3	Unknown Error	Parameter measured with error, sentinel value supplied.

WU	4	Sensor Warm-up	Sensor is warming up, sentinel value supplied.
DIS	5	Sensor Warning	Parameter measured but does not meet normal quality criteria. The sensor has sustained moderate damage, or the recommended lifespan has been reached.
CAL	6	Sensor Calibrating	Sensor is calibrating, calibration value supplied.
OL	7	Sensor Missing	Sensor communication failed, sentinel value supplied. Make sure the sensor cap is installed and properly seated.

7. Calibration

Connect the ODO-TX to a computer using the RS485 connection and open Commkit communication. Alternately, connect the ODO-TX to an appropriate controller or PLC with calibration capability. If using a PLC or controller to calibrate, refer to your controller manual. You can either perform a one-point or two-point calibration as noted below.

7.1. One Point Calibration: Water-Saturated-Air 100% Saturation

1. Saturate a sponge with deionized water and insert it into the calibration cup.
2. Gently dry the probe and sensor cap with a paper towel. Make sure to remove all water and debris.
3. Place the ODO-TX probe in the calibration cup so the sensor surface is about 2.5 cm (1") above the sponge.
4. Wait 5 to 10 minutes for temperature stabilization, but do not leave the probe in the calibration cup for more than 30 minutes. Condensation can form on the sensor surface, which may result in false readings after calibration. If condensation occurs, remove and thoroughly dry the probe.
5. Once stable execute/complete single or first point calibration.
 - a. If using a PLC or controller to calibrate, refer to your controller manual.

7.2. Second Point (0%) of Two Point Calibration

1. Perform a one-point calibration as described above.
2. Remove the sponge from the calibration cup. Fill the cup to the fill line. This requires approximately 10 mL of fresh sodium sulfite solution.
3. Place the instrument in the calibration cup. Leave at least 13 mm (1/2") between the surface of the sensing material and the bottom of the calibration cup.
4. Make sure the sensor is completely submerged in the solution.
5. Allow at least five minutes for the temperature to stabilize.
6. Once stable execute/complete second point calibration.
 1. If using a PLC or controller to calibrate, refer to your controller manual.
7. After calibration, remove the probe. Detach the sensor. Thoroughly rinse the probe and sensor to remove all sodium sulfite solution.

7.3. Temperature and Concentration (ppm or mg/l) calibration

Calibration for these parameters can be completed as a one or two-point calibration method on a controller or PLC using respective reference meter.

Concentration calibration is automatically executed when calibrating the probe using Commkit

8. Maintenance

8.1. Cleaning

Probe maintenance includes cleaning the sensor cap, as well as the proper conditioning, preparation, and storage of the test system. With the membrane sensor cap and guard cap installed on ODO-TX, gently scrub the probe with a soft-bristled brush or nylon dish scrubber. Use Alconox or similar cleaning solution to remove grease or other matter. Soak in vinegar and DI water to remove mineral deposits or extensive fouling.

8.2. Replacing the Sensor Cap

The membrane Sensor Cap has a 2-year typical life after the sensor takes its first reading.

1. Remove the probe guard cap.
2. Use a lint-free cloth to remove any moisture from the probe.
3. Pull the used membrane sensor cap off of the sensor, without twisting.
4. Remove the existing O-rings from the sensor.



NOTICE

Do not touch or clean the lens with anything other than the supplied lens wipe.

5. Use your finger to apply a very light layer of silicone-based lubricant around the O-ring grooves.
6. Place the O-rings on the sensor. Apply another thin layer of lubricant to the O-rings and grooves.



NOTICE

Note: Do not transfer grease to the lens or sensor pins.

7. Remove the new cap from its sealed packaging and attach it to the sensor, being careful to press firmly, without twisting, until it seals over the lens. Make sure that the O-rings are not pinched or rolled between the cap and the sensor.
8. Replace the guard cap.
9. Each membrane cap comes factory calibrated, but for enhanced performance, perform a 1- or 2-point calibration to pair the new membrane sensor cap with the probe.

The ODO-TX series does not consist of any user-serviceable parts. The membrane is a consumable item and thus should only be replaced. If the guard Cap is damaged that should also be replaced. The optical system can not be serviced and thus users/technicians must not attempt to open the probe beyond removing the membrane sensor cap and the guard cap.

9. Spare Parts

Part #	Description
AM-ODO-TX-CAP	ODO-TX-Replacement Sensor Cap

Sensor Cap Storage

Prior to installation—Store in factory supplied container.

Installed—Store in the calibration chamber with the storage cap attached and a few drops of clean water.

10. Accessories

Part #	Description
AM-ODO-TX-CAL	Calibration Cap
AM-JB2	Junction box with integrated terminal strip
AM-HTA-R5	Ball Valve assembly for Hot-Tap insertion
AM-ARM-5	Submersion mounting kit
AM-TEE-R5	1" Union Tee with 3/4" adapter
AM-CFT-R5	Compression Fitting for 1" NPT sensors
AM-CBL	Extension cable

10.1. Calibration Cap

Calibrate the sensor with the Comm Kit Software or calibrate the sensor directly with your controller or PLC.

1-Point Calibration

The optical Rugged Dissolved Oxygen sensor is very stable. The factory calibration should produce readings within 3% accuracy. If you require readings with greater accuracy we recommend that you perform a 1-point, 100% water-saturated air calibration as described below.

Water-Saturated Air

1. Remove the storage cap from the top of the calibration chamber and replace it with the vented calibration cap.

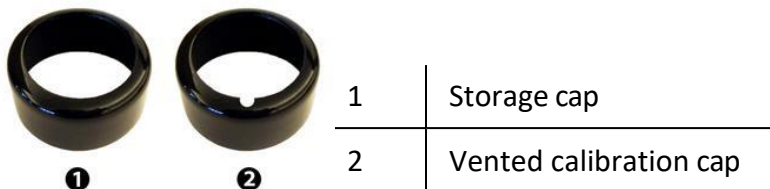

2. Place the sponge wafer in the bottom of the calibration chamber and saturate with approximately 10 mL water.
3. Gently dry the instrument and sensing material with a paper towel, making sure there is no water or debris on the instrument or on the sensing surface.
4. Place the instrument into the calibration chamber about 2.5 cm (1 in.) above the water-saturated sponge.



5. Allow 5 to 10 minutes for temperature stabilization prior to starting the calibration procedure. Do not leave the instrument in the calibration chamber for more than 30 minutes. This can allow condensation to form on the sensing material, which will produce false low readings after calibration. If condensation does occur, remove the instrument, dry the sensing material, place the instrument in the chamber, and calibrate.

10.2. Mounting

10.2.1. General Installation Requirements

Check the probe to ensure that no air bubbles have formed on the electrodes during submersion.

10.2.2. Submersion Mounting with the AM-ARM-5

The ODO-TX is a fully submersible sensor. Although not required, submersion hardware to protect the cable from wear and tear is advisable. The AM-ARM-5 consists of a 4-foot long CPVC pipe with a 1" FNPT fitting on the front end on which to mount the probe and a strain relief on the back end. A wire bracket, constructed of thick aluminum wire, is used to secure the arm onto the edge of a tank or basin.

To mount the ODO-TX on the AM-ARM-5:

1. Guide the probe cable from the 1" NPT fitting side from the front end of the submersion arm all the way through and back out the back.
2. Loosen the strain relief, thread the cable through, and tighten it.

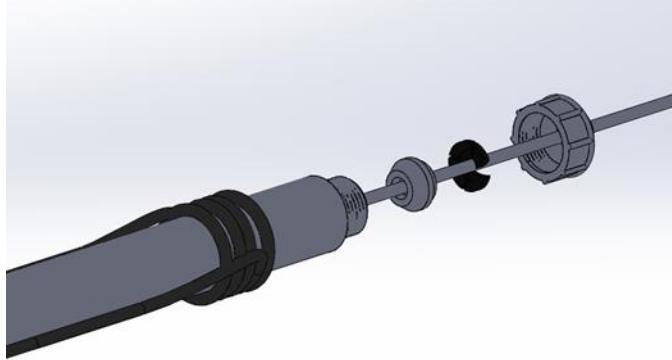

3. Slide the aluminum wire mounting bracket onto the probe.

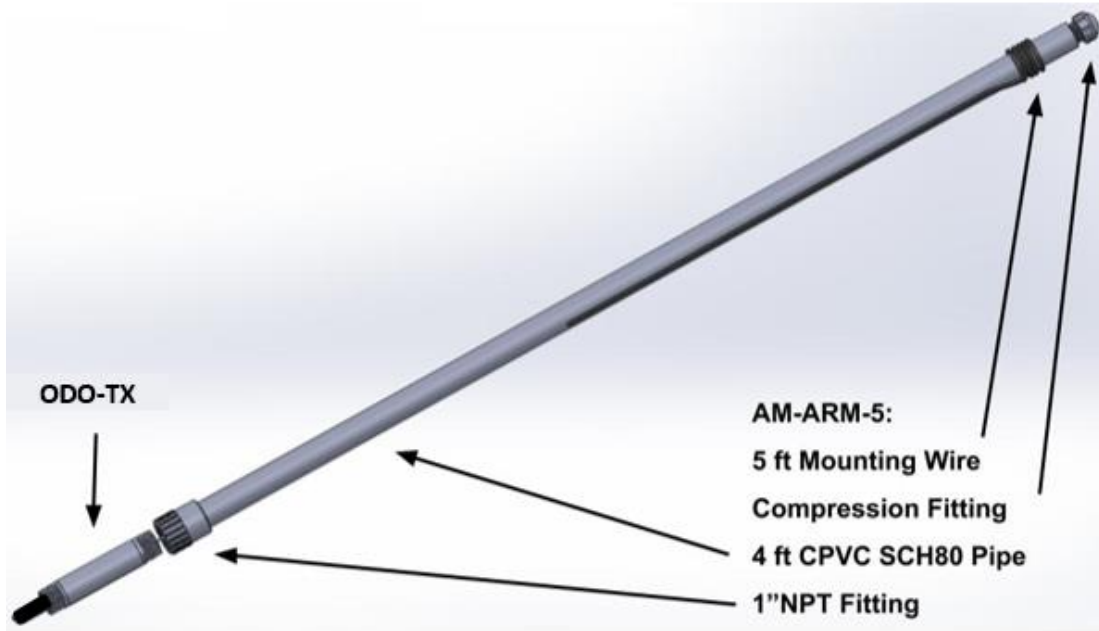

4. Apply sealant onto the back thread of the probe.
5. Screw the sensor (hand tight) into the 1" FNPT fitting on the front end.
6. Tighten the compression fitting (hand tight) on the back end.

10.2.3. Inline Mounting with the AM-TEE-5

In-line measurements must be made with a 1" tee adapter. An off the shelf tee fitting will work. For mounting that allows quick removal of the probe without twisting the cable, consider the AM-TEE-5. This customized tee consists of a 1" FNPT compression fitting for the probe and a large lock nut for securing the probe.

To mount the ODO-TX probe in the AM-TEE-5:

1. Insert split ring and nut over the sensor.

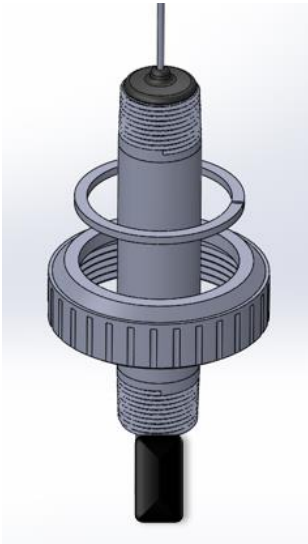

2. Screw the ODO-TX into the 1" Insert bushing.



3. Slide the bushing assembly into the tee and screw on the compression nut. Install lock nut into a groove to keep the nut attached to the assembly.

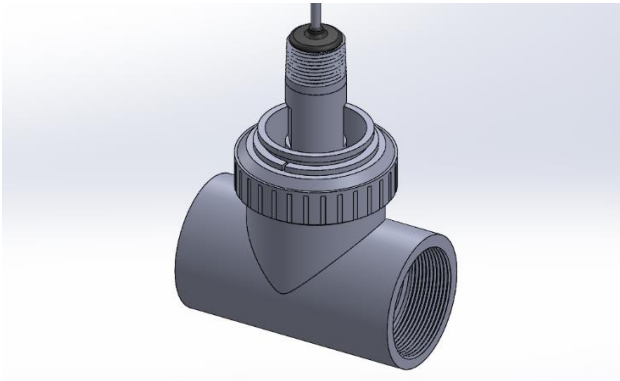

11. Troubleshooting

To troubleshoot the AM-ODO-TX connect it directly to the power supply avoiding, if possible, all interconnection, splices, and junction boxes. When the red and black wires are connected to the power supply (5-36 VDC), LEDs under the cap should start blinking (the ODO cap can be removed to observe the LED). If the LED's are not blinking – the sensor is not working.

The next testing level requires a multimeter in current mode. Without disconnecting the power connection add the black lead (COM) of the multimeter to the black wire and red wire (mA) to the blue or yellow wire. The expected reading in the air would be $\approx 100\%$ sat (or ≈ 8 ppm) which would result in 12mA for percent sat or ≈ 10 -11mA for ppm, temperature will be dependent on your settings. If the output is stuck at 4mA or 20 mA – the sensor is not working.

The sensor can also be connected via RS485 to a computer and using the Commkit software, the user can connect and get live readings. If the user is not able to connect, then the sensor is not working.

Please contact support@wateranalytics.net or call Water Analytics technical support 978.749.9949

12. Disposal

In accordance with local regulations, please dispose of this product at specified locations for electrical and electronic equipment. Please contact the local government/authority or party responsible from which you purchased this device. Should this device be passed on to other parties (for private or professional use), the content of this regulation must also be related.

13. Contact

Please contact us at support@wateranalytics.net or call us at 978-749-9949



100 School Street
Andover, MA 01810
978-749-9949
www.WaterAnalytics.net

This manual contains confidential and copyrighted information owned by Water Analytics. The contents of this document may not be reproduced, photocopied, or translated into another language without the

prior written consent of Water Analytics. RDO® is a registered trademark of In-Situ® Inc., Fort Collins, CO USA.

Water Analytics provides this material as-is and makes no warranties, express or implied, regarding its suitability for any specific purpose. Water Analytics shall not be held responsible for any errors or damages, whether incidental or consequential, arising from the use or performance of this material.

Under no circumstances shall Water Analytics be liable for any direct, incidental, or consequential damages resulting from the sale, manufacture, delivery, or use of any product.

Appendix A: Dissolved Oxygen Equations

Dissolved Oxygen Concentration

DO concentration is internally calculated in mg/L. Conversion to other units is as follows:

$$\mu\text{g/L} = 1000 * \text{mg/L}$$

Oxygen concentration C_o (mg/L) is calculated as:

$$C_o = 31.9988 \times 1E6 \times (\rho P_o / k_o M) (1 - \Theta_o) \times S_c$$

Where:

P_o is the partial pressure of O_2 in atmospheres.

$$P_{\text{torr}} = 759.999876 \times P_{\text{atm}}$$

S_c is the salinity correction:

$$\ln S_c = S(B_0 + B_1 T_s + B_2 T_s^2 + B_3 T_s^3) + C_0 S^2$$

$$B_0 = -6.246090 \times 10^{-3}$$

$$B_1 = -7.423444 \times 10^{-3}$$

$$B_2 = -1.048635 \times 10^{-2}$$

$$B_3 = -7.987907 \times 10^{-3}$$

$$C_0 = -4.679983 \times 10^{-7}$$

T_s is the scaled temperature:

$$T_s = \ln [(298.15 - t) / (273.15 + t)]$$

t is temperature in degrees C.

S is the salinity in PSU.

k_o is Henry's constant:

$$\ln k_o = 3.71814 + (5596.17/T) - (1,049,668/T^2)$$

T is temperature in Kelvin.

Θ_o is the negative of the second pressure coefficient:

$$\Theta_o = 0.000975 - (1.426 \times 10^{-5}t) + (6.436 \times 10^{-8}t^2)$$

t is temperature in degrees C.

ρ is the density of water in g/cm^3 :

$$\ln \rho = -0.589581 + (326.785/T) - (45,284.1/T^2)$$

T is the temperature in Kelvin.

Molar mass of water: $M = 18.0152$ g/mole

References:

Benson and Krause. Jr.. 1980. The concentration and isotopic fractionation of gases dissolved in freshwater in equilibrium with the atmosphere. *Limnol, Oceanogr*, 25(4), 662-671.

Gordon and Garcia. 1992. Oxygen Solubility in Seawater: Better Fitting Equations. *Limnol, Oceanogr*, 37(6), 1307-1312.

$$O_2\%Sat = O_2Reading / O_2100\%Sat$$

Where:

O₂ reading is the mg/L reading from the RDO Sensor.

O₂ 100% Sat is the theoretical saturation value in mg/L and is derived as:

$$O_2100\%Sat = 31.9988 \times 10^6 \times \rho \frac{[0.20946 \times (P - P_{wv})]}{k_o M} \times (1 - \Theta_o P) \times S_c$$

Where:

ρ is the density of water in g/cm³:

$$\ln \rho = -0.589581 + (326.785/T) - (45,284.1/T^2)$$

T is the temperature in Kelvin.

P is the atmospheric pressure in atm.

P_{wv} is the partial pressure of water vapor at saturation in atm:

$$\ln P_{wv} = 11.8571 - (3,840.70/T) - (216,961/T^2)$$

k_o is Henry's constant:

$$\ln k_o = 3.71814 + (5596.17/T) - (1,049,668/T^2)$$

T is the temperature in Kelvin.

Molar mass of water: M = 18.0152 g/mole

Θ_o is the negative of the second pressure coefficient:

$$\Theta_o = 0.000975 - (1.426 \times 10^{-5}t) + (6.436 \times 10^{-8}t^2)$$

t is temperature in degrees C.

S_c is the salinity correction:

$$\ln S_c = S(B_0 + B_1T_s + B_2T_s^2 + B_3T_s^3) + C_0S^2$$

$$B_0 = -6.246090 \times 10^{-3}$$

$$B_1 = -7.423444 \times 10^{-3}$$

$$B_2 = -1.048635 \times 10^{-2}$$

$$B_3 = -7.987907 \times 10^{-3}$$

$$C_0 = -4.679983 \times 10^{-7}$$

T_s is the scaled temperature:

$$T_s = \ln [(298.15 - t) / (273.15 + t)]$$

Where t is temperature in °C

S is the salinity in PSU

References:

Benson and Krause, Jr., 1980. The concentration and isotopic fractionation of gases dissolved in freshwater in equilibrium with the atmosphere. *Limnol, Oceanogr*, 25(4), 662-671.

Appendix B: Commkit

1. About CommKit

Comm Kit software allows you to configure and calibrate your dissolved oxygen probe on a Windows PC.

A link for installation can be found on our website or by using the QR code on your sensor.



2. Connecting to CommKit

- a. Connect the instrument to your PC.
- b. Launch Comm Kit.
- c. Leave the default communication settings alone when connecting for the first time.
- d. Press the Connect button at the bottom corner.

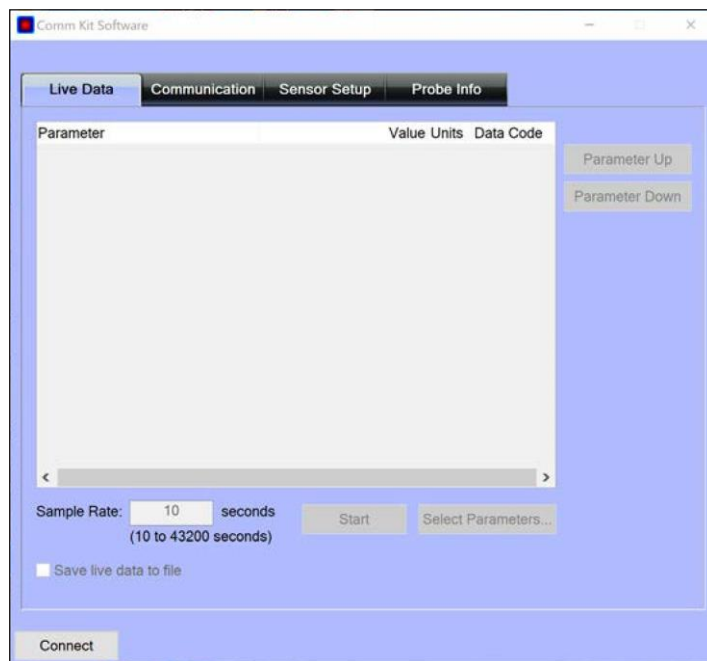

e. When a connection is successful, Comm Kit displays live readings from the instrument.



3. Communication tab to change Modbus or 4-20 mA settings.

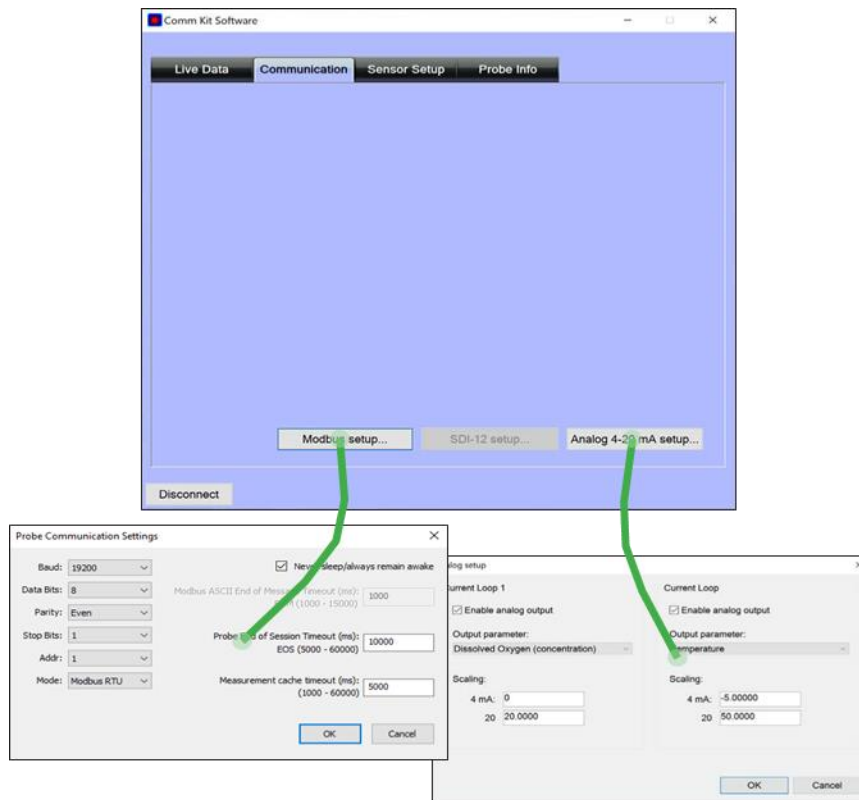

4. Sensor Set up

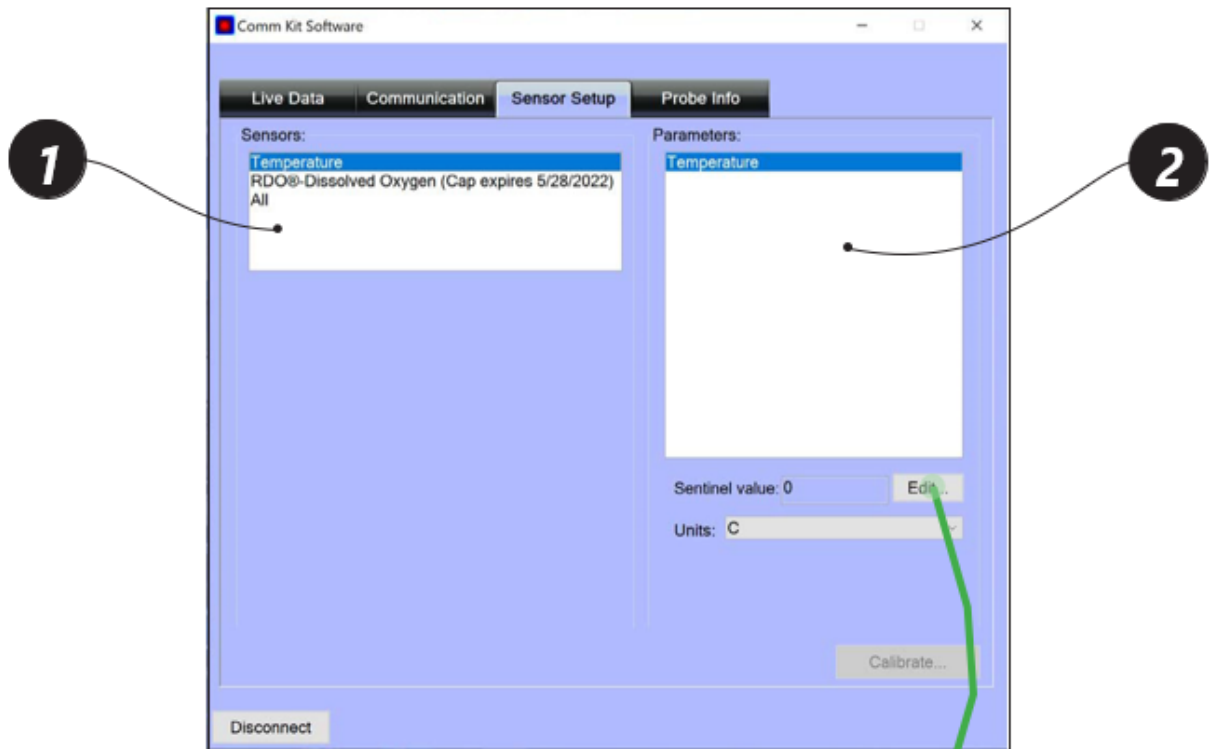

- 1 Use the tabs to navigate between functions.
- 2 Scroll through the parameters in the Live Data tab with the **Up** and **Down** buttons.

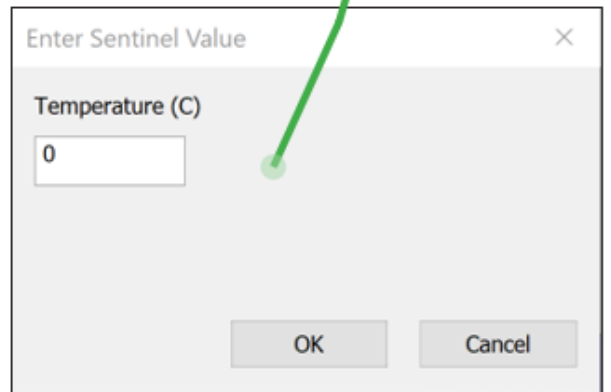

5. Probe Info Screen

Comm Kit Software

Application version: 1.0.8.0
 Probe type: RDO Instrument
 Serial number: 756680
 Firmware version: 1.16

Apply Serial Number

Enter S/N

Applying "0" resets to the RDO Core S/N.

Applying a serial number performs a factory reset. This removes user calibrations and configurations. All settings revert to factory defaults.

Apply Cancel

Restore factory default settings to the sensor?
 This will remove all user calibration, reset units configuration and restore all other settings to factory defaults.
 Please confirm.

Yes No

Comm Kit will ask for confirmation before resetting.

Apply Serial Number... Update Firmware... Diagnostics... Factory Reset

Disconnect

Firmware Update

Firmware file: Select file...

Firmware version:

Update Device Cancel

Comm Kit Software Diagnostics

RDO	Color	Unit	Level	Probe
Default Barometric Pressure	1013.2500		Calibration Slope:	1.0000
Live Barometric Pressure (mBar)	1013.2500		Calibration Offset:	0.0000
Default Salinity Value (PSU)	0.0000		Cal 100% DO (mg/l):	0.0000
Live Salinity Value (PSU)	0.0000		Cal 100% Temp (C):	0.0000
			Cal 100% Salinity (PSU):	0.0000
			Cal 100% Baro (mBar):	1013.2500
			Cal 0% DO (mg/l):	0.0000
			Cal 0% Temp (C):	0.0000
RDO Core Serial Number:	714682			
RDO Sensor Cap status:	Normal			
Good Messages:	676		Cache Timeout (ms):	5000
Bad Messages:	15		External Power Voltage (mV):	9280
Exceptions:	0			

Reset OK

- 1 Click **Update Firmware** to install the latest firmware.
- 2 Then click **Select file** and choose your firmware.
- 3 The version number will appear in the Firmware version box.

The diagnostics tabs display critical sensor, sensor cap, calibration, and power supply info.

6. Saving Live readings to Spreadsheet

To save live readings to a spreadsheet, first select the parameters you are looking to save and then click the “Save live data to file” checkbox. Once you have saved the log’s location and you’re ready to begin recording data, press the Start button. Comm Kit creates a spreadsheet file with one row for each reading.

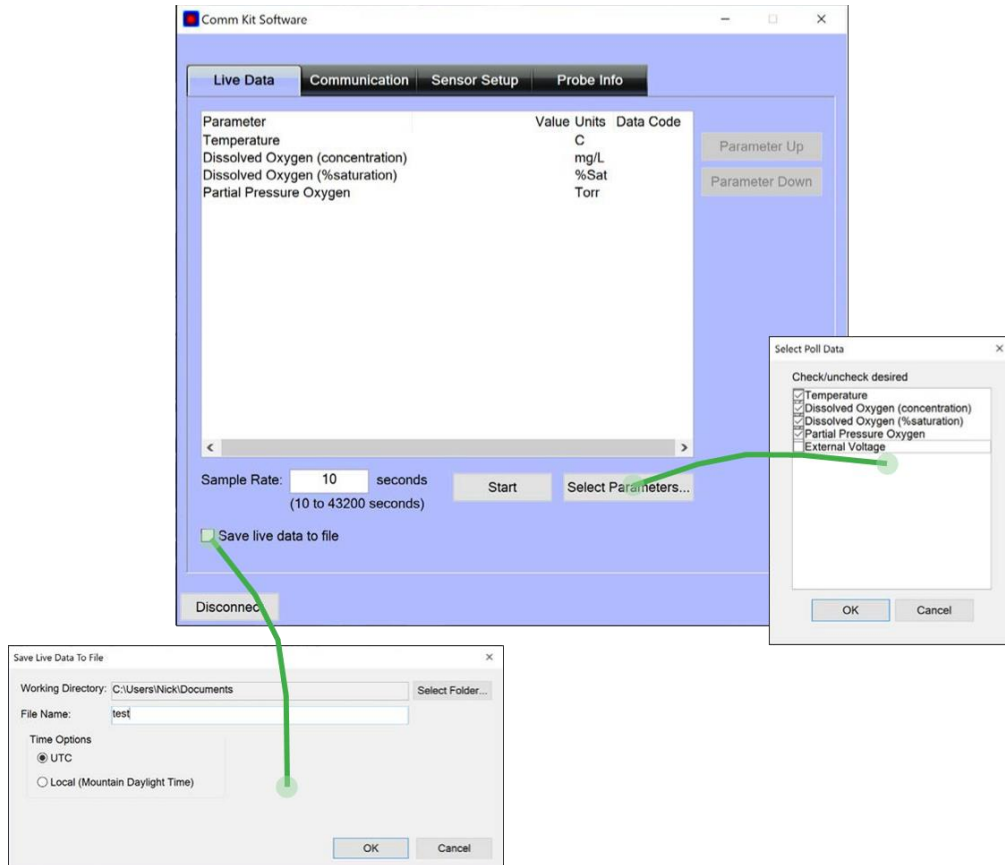

d Choose the parameters Comm Kit saves to a data file with the Select Parameters button.

Appendix C: Definitions

Live Salinity Value

The live salinity value is used to correct the oxygen concentration value for salinity. Values must be written in Practical Salinity Units (PSU) in the range 0 to 42 PSU. This is not a measured parameter.

Default Salinity Value

The default salinity value is loaded into the live salinity value register when power is first applied to the probe. The default salinity value is used in calculations until a live salinity value is written. This is not a measured parameter.

Live Barometric Pressure

The live barometric pressure is used in the calculation of percent saturation and to determine the theoretical saturation point during calibration. Values must be written in millibars in the range 506.625 to 1114.675 mbar. This is not a measured parameter.

Default Barometric Pressure

The default barometric pressure is loaded into the live barometric pressure register when power is applied to the probe. The default barometric pressure is used in calculations until a live barometric pressure is written. This is not a measured parameter.

100% Saturation Calibration Values

These values represent the sensor conditions while the probe is in a 100% saturation calibration environment. These are not measured values, they are written by the controller during the calibration process.

Writes to these registers are only accepted if the probe is in the calibration mode. The probe will return exception 0x85 (invalid device command sequence) if an attempt is made to write these registers when the calibration mode is off.

0% Saturation Calibration Values

These values represent the sensor conditions while the probe is in a 0% saturation calibration environment. These are not measured values, they are written by the controller during the calibration process.

Writes to these registers are only accepted if the probe is in the calibration mode. The probe will return exception 0x85 (invalid device command sequence) if an attempt is made to write these registers when the calibration mode is off.

Calibration Slope and Offset

These values represent the slope and offset that will be applied to the raw concentration reading from the sensor to generate the final values reported by the sensor parameters. These registers may be written independently of the normal internal calibration procedure.

Entering Calibration Registers

The sensor is calibrated using the following procedure.

1. Optional: Read the Sensor Data Cache Timeout register 9463 and store the value.
2. Write the Sensor Data Cache Timeout register 9463 to a value less than your intended sample rate and greater than 1000 milliseconds. This will ensure that you get new sensor readings during the stabilization process.
3. Optional: Read the temperature units register 0049 and saturation units register 0041 and store their values.
4. Write the temperature units register 0049 to its default value (1) and write the saturation units register 0041 to its default value (117).
5. Write the Calibration Mode On command (0xE000) to the sensor command register 9305.
6. Update the live salinity and barometric pressure registers if necessary.
7. Prompt the user to place the probe in a 100% saturation environment.
8. Read the oxygen concentration and temperature parameters. When these values have reached equilibrium, record them in their respective 100% saturation calibration registers. Write the current live salinity and barometric pressure readings to their respective calibration registers.
9. Place the sensor in a 0% saturation environment. When these registers have reached equilibrium, record them in their respective 0% saturation calibration registers. If a zero calibration is not to be performed, these registers can be set to zero or left at their previous values.
10. Write the Calibration Update command (0xE001) to the sensor command register. The sensor will calculate a new slope and offset, write the current time to the last user calibration time register, and set the next user calibration time register to zero (disabled). If the concentrations at 100% and 0% saturation are equal, the probe will return an exception response with code 0x97 (invalid calibration) and not attempt to compute a new slope and offset due to possible division by zero. If the slope does not calculate between 0.85 and 1.20 inclusive, or if the offset does not calculate between -0.2 and +0.2 inclusive, then the probe will return an exception response with code 0x97 (invalid calibration). The slope and offset will be available for read but will not be committed to flash.
11. Optional: Read the last user calibration time register, add the next calibration interval, and write the result to the next user calibration time register.
12. Write the Calibration Mode Off command (0xE002) to the sensor command register to place the sensor in normal operation. If the calibration mode is turned off without a calibration update command, or the calibration command returned an exception, the previous calibration shall be restored.
13. Optional: If you saved the temperature and saturation parameter units at the start of the process, write the original values back.
14. Optional: If you saved the Sensor Data Cache Timeout register 9463 at the start of the process, write the original value back.