

Pedak Toroidal Conductivity Sensors with 4-20mA Interface

Models: PBKIN50-4-20PM
Conductivity range (compensated): 0-2.5 mS, 0-50mS or 0-250 mS
Temperature compensation: 1.7 % per °C (From 25°C)

Feature table:

Model	Temperature	Fixing Thread	Interface	Electronics
PBKIN50-4-20mA	0-50.0°C	½" BSP Parallel	4-20mA	Internal

The 'B' series toroidal conductivity sensors overcome many of the difficulties associated with conventional toroidal sensors.

The signal processing electronics is incorporated in the sensor's body and is permanently paired with the sensor cell.

This allows the sensor to be pre-calibrated at the factory.

The sensors are available in two ranges: 0-2.5mS, 0-50mS and 0-250mS.

The 4-20mA converter circuit is housed in an encapsulated module on the cable, situated close to the sensor body.

The sensor requires a single 12-24V DC supply, and has 4-20mA current loop output, all in a single 6-wire unscreened cable.

The body of the sensor can be flange mounted and is available in two thread sizes: ½" BSP (black) or ¾" BSP (Beige).

The sensor has built-in temperature measurement circuit which is used to calculate temperature compensation of the conductivity output value.

Temperature compensation is carried out within the sensor electronics, the default percentage value is 1.7%/°C.

The electronics package of the sensor has been developed to be compliant with CE RF industrial fields and does not require any shielded cables for connection.

The default cable length is 3 meters unless specified otherwise at time of order.



Sensor connections.

Red	Power supply +12V to 24V DC @ 50 mA
Black	Power supply 0V
Yellow	4-20mA current loop output positive lead
Green	4-20mA current loop output negative lead (return)
Orange	Serial data output (for calibration only) Output Levels: 0 = <0.6V, 1 = >4.3V
Brown	Serial data input (for calibration only) Input Levels: 0 = <1.5V, 1 = +4.0V to +5.0V

Connection diagram of the sensor is shown in figure 1.

The orange and brown wires are used for factory testing and calibration only and in typical sensor operation mode should be left unconnected.

These wires should on no account be connected to the power supply or any part of the 4-20ma loop, damage to the sensor will result.

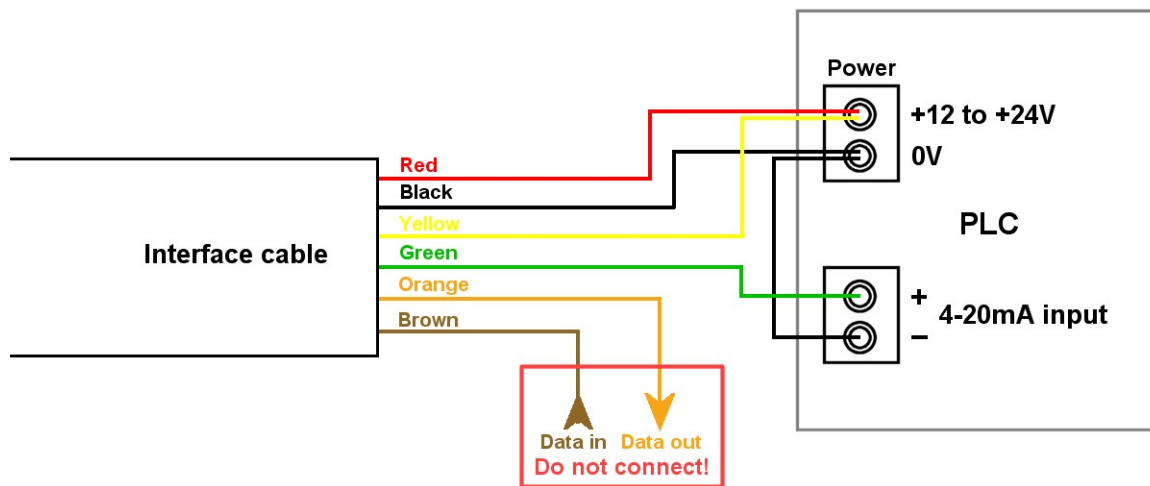

Figure 1. Connecting the sensor to the PLC

Mechanical mounting.

The sensors can be fitted into tanks using a back nut and sealing washer or into the side of a 'T' piece inline with a pipe using an adaptor.

Note however that there needs to be a minimum clearance around the end of the probe as specified in the drawings below.

The probe should only be held during tightening using the hexagon on the body, on no account should the probe be tightened using the head or a bar through the hole in the head, this will damage the probe.

PBKIN50-4-20PM
Dimensions

