

# Solumentrix PH485DIN din rail mount pH sensor to 4-20mA & RS485 interface module.

Issue 1 data sheet.

## Features:

- 36mm wide Din module.
- Isolated 4-20ma output.
- 2 x dual colour status LED's, one for PH calibration state and one to indicate modbus Comms.
- 1 x manual calibration button.
- Pluggable input and output connections

## RS485 registers can adjust:

- Slave ID (default 247)
- Baud rate, 9600, 14400, 19200, 38400, 57600 or 115200
- Parity, odd, even or none (not yet supported)
- Stop bits , 1 or 2 (not yet supported)
- 4-20mA output range.
- Read temperature & pH.
- Temperature and pH calibration.
- Testing of 4-20mA output.



## Default 4-20mA output:

- 20.0mA = pH 14
- 12.0mA = pH 7
- 4.0mA = pH 0

## Connections

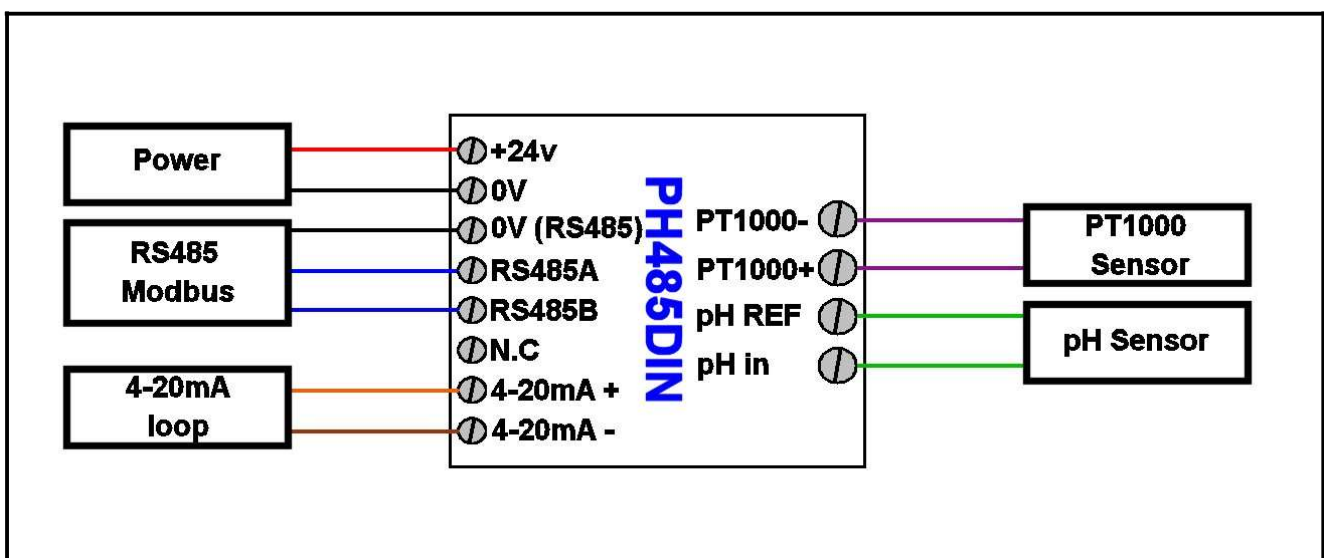

## 8 pin Output connector

1	+24V DC @ 30mA	Power supply
2	0V	Power supply return.
3	0V	RS485 0V
4	RS485A	
5	RS485B	
6	N.C	
7	Loop +	4-20mA Loop
8	Loop -	4-20mA Loop return

N.B: The 4-20ma output is isolated so the 4-20ma loop can be power from the supply on pins 1 & 2 if required.

## 4 pin Input connector

A	pH	Ph sensor Input connection.
B	Ref	Ph sensor Reference connection.
C	PT1000+	PT1000 temperature sensor
D	PT1000-	PT1000 temperature sensor

## CAL LED

This indicates the calibration status,

There is a long delay (approx 4 seconds) and then the calibration led will flash 3 times with a 1 second gap between each flash.

Each flash indicates the calibration status at 4, 7 and 10pH points respectively.

If the 4 and 10 pH points are to be calibrated then the pH 7 point must be calibrated first.

## Modbus LED

This will show a Yellow flash on receipt of a modbus command address to the module.

If the command is valid but not currently permitted (usually because the module isn't in setting mode) or the value is out of range then this LED will flash Red.

## Manual pH calibration.

N.B: PH 7 must be calibrated first

The module will measure the pH value and automatically calibrate the correct pH point, 4, 7 or 10pH

Place the PH sensor in a suitable calibration solution, stir it and allow the pH reading to stabilise.

When stable, press and hold the calibration button, after 10 seconds the CAL LED will start fast flashing Green, the calibration button can be released at this point.

The green flashing will continue for 10 seconds while the module samples the PH values.

At this point the CAL LED will either light Green for 5 seconds if the calibration passed, or light Red for 5 seconds if the calibration failed.

The calibration will fail if the pH of the calibration solution is more than xxx pH above or below 4, 7 or 10 pH

The calibration will also fail if you try to calibrate the pH 4 or 10 points before calibration of the pH7 point has been done.

It is possible to recalibrate any of the point by repeating the procedure above.

### RS485 Modbus operation.

The RS485 default comms protocol is 19200 baud, 8 data bits, Even parity and 1 stop bit.

The baud rate can be selected from 9600, 14400, 19200, 38400, 57600 or 115200 Baud using a register.

Changing the Parity and the stop bits is only a factory option at the moment

The default slave address for the module is 247, it will also respond to a broadcast on address 0

The Modbus interface currently accepts only function 3 (Read Holding registers ) and function 6 (Write Single Register).

All registers are unsigned 16 bit values.

The user RS485 Modbus registers are as follows:

Reg Name	Min	Max	Setting			Notes
			Read only	mode only	Saved	
0 Slave Address	1	254		✓	✓	Default 247
1 Baud rate	0	5		✓	✓	See below #1
2 Parity	0	2			✓	Not currently implemented
3 Stop bits	1	2			✓	Not currently implemented
4 PH Result	0	14000	✓			7000 = 7.000pH
5 ORP Result	0	0	✓			Not currently implemented
6 Temperature result	0	9999	✓			2500 = 25.00 °C
7 Event counter	0	65535	✓			Count of RS485 accesses
8 Software version	0	0	✓			210 = version 2.10
9 4-20mA 4mA pH	0	14000		✓	✓	Default = 0 = 0pH
10 4-20mA 20mA pH	0	14000		✓	✓	Default = 14000 = 14.000pH Set 4-20mA, 12000=12mA
11 4-20mA test	0	20000		✓		See below #4
12 Calibration status	0	7		✓	✓	See below #2
13 Setting mode	0	65535				See below #3
19 PT1000 offset cal	0	65535		✓	✓	0 default
20 PT1000 gain cal	1	65535		✓	✓	32768 default
21 4-20 mA DAC offset cal	0	65535		✓	✓	Factory set
22 4-20 mA DAC gain cal	1	65535		✓	✓	Factory set

Please note: other registers are used for factory testing and calibration and should not be accessed or written to.

Note #1: Register 1

The possible baud rates are 0 = 9600, 1 = 14400, 2 = 19200, 3= 38400, 4 = 57600 & 5 = 115200 baud.

Note #2: Register 12

This show the status of the calibration at the 3 points, 4, 7 & 10 pH similar to the LED flashes.

Value	4pH cal	7pH cal	10pH cal
0			
2		✓	
3	✓	✓	
6		✓	✓
7	✓	✓	✓

Note #3: Register 13

To enable changing of certain settings registers the module needs to be put into setting mode.

This is achieved by putting the value 48500 into register 13

Note #4: Register 11

This register lets you manually set the 4-20mA output to specific values. If the value in this register is less than 4000 (=4mA) then the 4-20mA output shows the current pH as normal.

If the value in register 11 is between 4000 (=4.000mA) and 20000 (=20.000mA) then the 4-20mA output is set to that value.

This is useful for calibrating the 4-20mA output using registers 21 and 22. This is done at the factory but please ask if you require more details.

For more information or support please contact [info@solumetrix.co.uk](mailto:info@solumetrix.co.uk)

Solumetrix Ltd, 98 King Georges Avenue, Coventry, CV6 6FF UK

UK +44 (0)2477-350015 US 8016934047

[www.solumetrix.co.uk](http://www.solumetrix.co.uk)